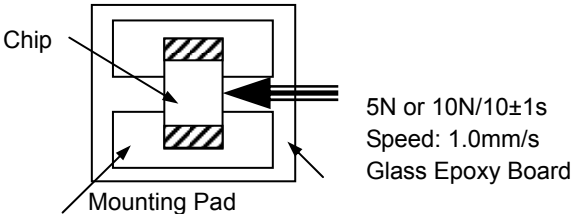
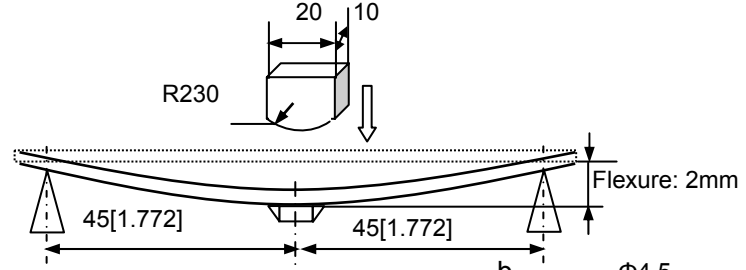
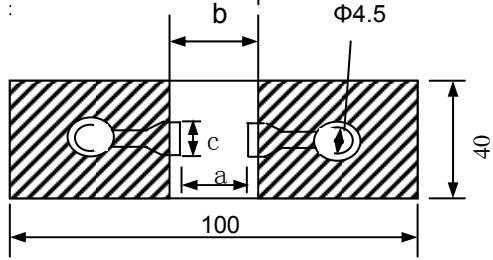
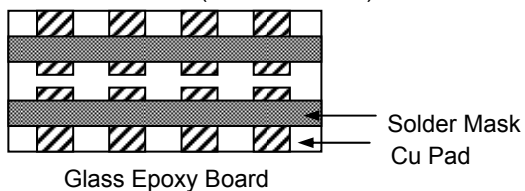

Chip Ferrite Bead (GZ/SZ/PZ/HZ/HPZ series)/Chip Ferrite Bead Array (ARZ series)

Items	Requirements	Test Methods and Remarks																				
1. Operating Temperature Range	GZ&SZ&HZ&ARZ series: -55℃ to +125℃ PZ&HPZ series: -40℃ to +85℃																					
2. Storage Temperature Range	GZ&SZ&HZ&ARZ series: -55℃ to +125℃ PZ&HPZ series: -40℃ to +85℃																					
3. Terminal Strength	No removal or split of the termination or other defects shall occur.	<p>① Solder the chip to the testing jig (glass epoxy board shown as the following figure) using eutectic solder. Then apply a force in the direction of the arrow.</p> <p>② 5N force for 1005 and 1608 series</p> <p>③ 10N force for 2012 and 3216 series</p> <p>④ Keep time: 10±1s</p> 																				
4. Resistance to Flexure	No visible mechanical damage.	<p>① Solder the chip to the test jig (glass epoxy board) using a eutectic solder. Then apply a force in the direction shown as the following figure.</p> <p>② Flexure: 2mm</p> <p>③ Pressurizing Speed: 0.5mm/sec</p> <p>④ Keep time: ≥30 sec</p>  <p>Unit: mm [inch]</p> <table border="1" data-bbox="454 1332 829 1512"> <thead> <tr> <th>Type</th> <th>a</th> <th>b</th> <th>c</th> </tr> </thead> <tbody> <tr> <td>1005[0402]</td> <td>0.4</td> <td>1.5</td> <td>0.5</td> </tr> <tr> <td>1608[0603]</td> <td>1.0</td> <td>3.0</td> <td>1.2</td> </tr> <tr> <td>2012[0805]</td> <td>1.2</td> <td>4.0</td> <td>1.65</td> </tr> <tr> <td>3216[1206]</td> <td>2.2</td> <td>5.0</td> <td>2.0</td> </tr> </tbody> </table> 	Type	a	b	c	1005[0402]	0.4	1.5	0.5	1608[0603]	1.0	3.0	1.2	2012[0805]	1.2	4.0	1.65	3216[1206]	2.2	5.0	2.0
Type	a	b	c																			
1005[0402]	0.4	1.5	0.5																			
1608[0603]	1.0	3.0	1.2																			
2012[0805]	1.2	4.0	1.65																			
3216[1206]	2.2	5.0	2.0																			
5. Vibration	<p>① No visible mechanical damage.</p> <p>② Impedance change: Within ±20%.</p>	<p>① Solder the chip to the testing jig (glass epoxy board shown as the following figure) using eutectic solder.</p> <p>② The chip shall be subjected to a simple harmonic motion having total amplitude of 1.5 mm, the frequency being varied uniformly between the approximate limits of 10 and 55 Hz.</p> <p>③ The frequency range from 10 to 55 Hz and return to 10 Hz shall be traversed in approximately 1 minute. This motion shall be applied for a period of 2 hours in each 3 mutually perpendicular directions (total of 6 hours).</p> 																				

Chip Ferrite Bead (GZ/SZ/PZ/HZ/HPZ series)/Chip Ferrite Bead Array (ARZ series)

Items	Requirements	Test Methods and Remarks
6. Dropping	① No visible mechanical damage. ② Impedance change: Within $\pm 20\%$ .	Drop chip bead 10 times on a concrete floor from a height of 100 cm.
7. Temperature	Impedance change should be within $\pm 20\%$ of initial value measuring at 20°C.	Temperature range: GZ&SZ&HZ&ARZ series: -55°C to +125°C PZ&HPZ series: -40°C to +85°C Reference temperature: +20°C
8. Solderability	① No visible mechanical damage. ② Wetting shall be exceeded 95% coverage.	① Solder temperature: 240 $\pm$ 2°C ② Duration: 3 sec. ③ Solder: Sn/3.0Ag/0.5Cu ④ Flux: 25% Resin and 75% ethanol in weight
9. Resistance to Soldering Heat	① No visible mechanical damage. ② Wetting shall be exceeded 95% coverage. ③ Impedance change: Within $\pm 20\%$	① Solder temperature: 260 $\pm$ 3°C ② Duration: 5 sec. ③ Solder: Sn/3.0Ag/0.5Cu ④ Flux: 25% Resin and 75% ethanol in weight. ⑤ The chip shall be stabilized at normal condition for 1~2 hours before measuring.
10. Thermal Shock	① No visible mechanical damage. ② Impedance change: Within $\pm 20\%$ .	① Temperature and time: GZ&SZ&HZ&ARZ series: -55°C for 30 $\pm$ 3 min $\rightarrow$ 125°C for 30 $\pm$ 3min. PZ&HPZ series: -40°C for 30 $\pm$ 3 min $\rightarrow$ 85°C for 30 $\pm$ 3min. ② Transforming interval: Max. 20 sec ③ Tested cycle: 100 cycles ④ The chip shall be stabilized at normal condition for 1~2 hours before measuring. 
11. Resistance to Low Temperature	① No visible mechanical damage. ② Impedance change: Within $\pm 20\%$ .	① Temperature: GZ&SZ&HZ&ARZ series: -55 $\pm$ 2°C PZ&HPZ series: -40 $\pm$ 2°C ② Duration: 1000 <sup>+24</sup> hours ③ The chip shall be stabilized at normal condition for 1~2 hours before measuring.
12. Damp Heat (Steady States)	① No visible mechanical damage. ② Impedance change: Within $\pm 20\%$ .	① Temperature: 55 $\pm$ 2°C ② Humidity: 90% to 95% RH ③ Duration: 1000 <sup>+24</sup> hours ④ The chip shall be stabilized at normal condition for 1~2 hours before measuring.
13. Loading Under Damp Heat	① No visible mechanical damage. ② Impedance change: Within $\pm 20\%$ .	① Temperature: 55 $\pm$ 2°C ② Humidity: 90% to 95% RH ③ Duration: 1000 <sup>+24</sup> hours ④ Applied current: Rated current ⑤ The chip shall be stabilized at normal condition for 1~2 hours before measuring.
14. Loading at High Temperature (Life Test)	① No visible mechanical damage. ② Impedance change: Within $\pm 20\%$ .	① Temperature: GZ&SZ&HZ&ARZ series: 125 $\pm$ 2°C PZ&HPZ series: 85 $\pm$ 2°C ② Duration: 1000 <sup>+24</sup> hours ③ Applied current: Rated current. ④ The chip shall be stabilized at normal condition for 1~2 hours before measuring.

Chip 3-Terminal EMI Filters (MFL series)

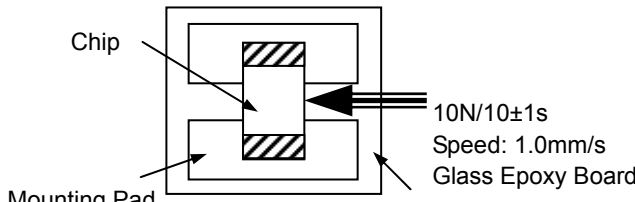
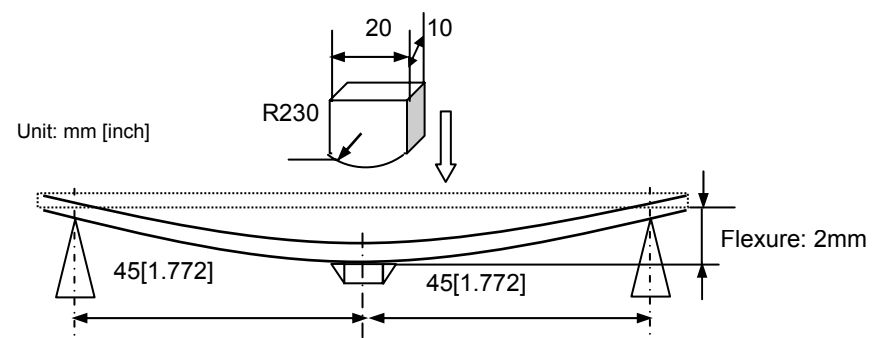
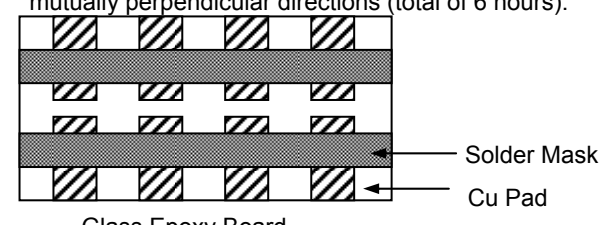
Items	Requirements	Test Methods and Remarks
1. Operating Temperature Range		-40°C to +85°C
2. Storage Temperature Range		-40°C to +85°C
3. Terminal Strength	No removal or split of the termination or other defects shall occur.	<p>① Solder the chip to the testing jig (glass epoxy board shown as the following figure) using eutectic solder. Then apply a force in the direction of the arrow.</p> <p>② 10N force for 2012 series</p> <p>③ Keep time: 10±1s</p>  <p>10N/10±1s Speed: 1.0mm/s Glass Epoxy Board</p>
4. Resistance to Flexure	No visible mechanical damage.	<p>① Solder the chip to the test jig (glass epoxy board) using a eutectic solder. Then apply a force in the direction shown as the following figure. Solder the chip to the test jig (glass epoxy board) using eutectic solder. Then apply a force in the direction.</p> <p>② Flexure: 2mm</p> <p>③ Pressurizing Speed: 0.5mm/sec.</p> <p>④ Keep time: ≥30 sec.</p>  <p>Unit: mm [inch]</p> <p>Flexure: 2mm</p>
5. Vibration	No visible mechanical damage.	<p>① Solder the chip to the testing jig (glass epoxy board shown as the following figure) using eutectic solder.</p> <p>② The chip shall be subjected to a simple harmonic motion having total amplitude of 1.5mm, the frequency being varied uniformly between the approximate limits of 10 and 55 Hz.</p> <p>③ The frequency range from 10 to 55 Hz and return to 10 Hz shall be traversed in approximately 1 minute. This motion shall be applied for a period of 2 hours in each 3 mutually perpendicular directions (total of 6 hours).</p>  <p>Solder Mask Cu Pad Glass Epoxy Board</p>
6. Dropping	No visible mechanical damage.	Drop the chip 10 times on a concrete floor from a height of 100 cm.
7. Solderability	<p>① No visible mechanical damage.</p> <p>② Wetting shall be exceeded 75% coverage.</p>	<p>① Solder temperature: 240±2°C</p> <p>② Duration: 3 sec.</p> <p>③ Solder: Sn/3.0Ag/0.5Cu</p> <p>④ Flux: 25% Resin and 75% ethanol in weight</p>

Chip 3-Terminal EMI Filters (MFL series)

Items	Requirements	Test Methods and Remarks
8. Resistance to Soldering Heat	No visible mechanical damage.	① Solder temperature: 260±3℃ ② Duration: 5 sec. ③ Solder: Sn/3.0Ag/0.5Cu ④ Flux: 25% Resin and 75% ethanol in weight. ⑤ The chip shall be stabilized at normal condition for 1~2 hours before measuring.
9. Thermal Shock	① No visible mechanical damage. ② Insulation resistance: MFL-SP: 500MΩ Min. MFL-ST: 20MΩ Min.	① Temperature and time: -40℃ for 30±3 min→85℃ for 30±3min. ② Transforming interval: Max. 20 sec. ③ Tested cycle: 100 cycles ④ The chip shall be stabilized at normal condition for 1~2 hours before measuring. 
10. Resistance to Low Temperature	① No visible mechanical damage. ② Insulation resistance: MFL-SP: 500MΩ Min. MFL-ST: 20MΩ Min.	① Temperature: -40±2℃ ② Duration: 1000 <sup>+24</sup> hours ③ The chip shall be stabilized at normal condition for 1~2 hours before measuring.
11. Damp Heat (Steady States)	① No visible mechanical damage. ② Insulation resistance: MFL-SP: 500MΩ Min. MFL-ST: 20MΩ Min.	① Temperature: 40±2℃ ② Humidity: 90% to 95% RH ③ Duration: 1000 <sup>+24</sup> hours ④ The chip shall be stabilized at normal condition for 1~2 hours before measuring.
12. Loading Under Damp Heat	① No visible mechanical damage. ② Insulation resistance: MFL-SP: 500MΩ Min. MFL-ST: 20MΩ Min.	① Temperature: 40±2℃ ② Humidity: 90% to 95% RH ③ Duration: 1000 <sup>+24</sup> hours ④ Applied current: Rated current ⑤ The chip shall be stabilized at normal condition for 1~2 hours before measuring.
13. Loading at High Temperature (Life Test)	① No visible mechanical damage. ② Insulation resistance: MFL-SP: 500MΩ Min. MFL-ST: 20MΩ Min.	① Temperature: 85±2℃ ② Duration: 1000 <sup>+24</sup> hours ③ Applied current: Rated current ④ The chip shall be stabilized at normal condition for 1~2 hours before measuring.

Chip Common Mode Choke Coil (SDCW series)

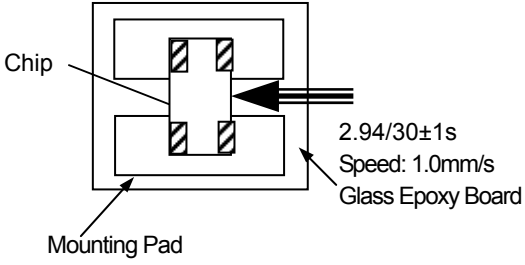
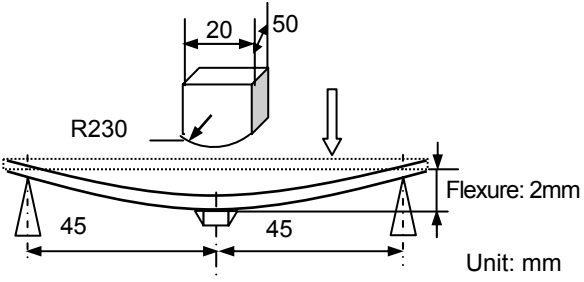
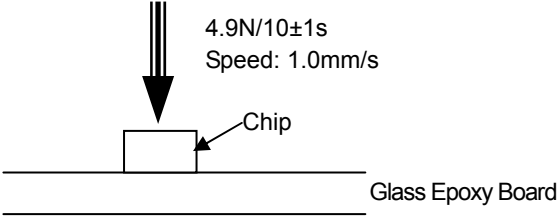
Item	Requirements	Test Methods and Remarks
1. Operating Temperature Range		-40°C to +85°C
2. Storage Temperature Range		-40°C to +85°C
3. Terminal strength	No removal or split of the termination or other defects shall occur.	<p>① Solder the chip to the testing jig (glass epoxy board shown as the following figure) using eutectic solder. Then apply a force in the direction of the arrow.</p> <p>② 2.94N force for 2012 series</p> <p>③ Keep time: 30±1s</p> 
4. Resistance to Flexure	No visible mechanical damage.	<p>① Solder the chip to the test jig (glass epoxy board) using eutectic solder. Then apply a force in the direction shown as the following figure.</p> <p>② Flexure: 2mm</p> <p>③ Pressurizing Speed: 0.5mm/sec</p> <p>④ Keep time: 30±1s</p> 
5. Core Body Strength	No visible mechanical damage.	<p>① Solder the chip to the testing jig (glass epoxy board) using eutectic solder. Then apply a force in the direction of the arrow.</p> <p>② 4.9N force for 2012 series</p> <p>③ Keep time: 10±1s</p> 

Chip Common Mode Choke Coil (SDCW series)

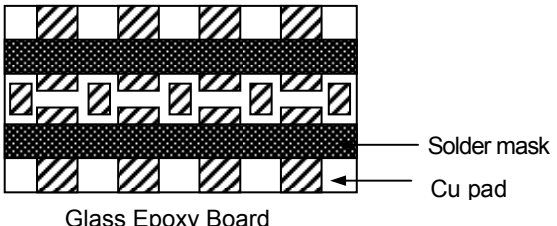
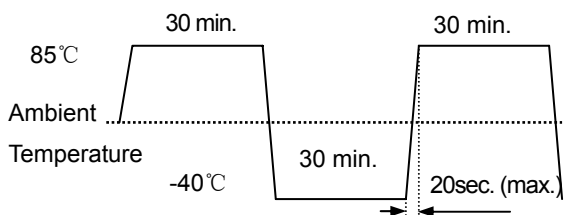
Item	Requirements	Test Methods and Remarks
6. Vibration	No visible mechanical damage.	① Solder the chip to the testing jig (glass epoxy board shown as the following figure) using eutectic solder. ② The chip shall be subjected to a simple harmonic motion having total amplitude of 1.5mm, the frequency being varied uniformly between the approximate limits of 10 and 55 Hz. ③ The frequency range from 10 to 55 Hz and return to 10 Hz shall be traversed in approximately 1 minute. This motion shall be applied for a period of 2 hours in each 3 mutually perpendicular directions (total of 6 hours). 
7. Dropping	No visible mechanical damage.	Drop the chip 10 times on a concrete floor from a height of 100 cm.
8. Solderability	① No visible mechanical damage. ② Wetting shall be exceeded 95% coverage.	① Solder temperature: 240±2℃ ② Duration: 3sec. ③ Solder: Sn/3.0Ag/0.5Cu ④ Flux: 25%Resin and 75% ethanol in weight.
9. Resistance to soldering heat	① No visible mechanical damage. ② Impedance change: Within ±20%. ③ Insulation Resistance: 10MΩ Min.	① Solder temperature: 260±3℃ ② Duration: 5 sec. ③ Solder: Sn/3.0Ag/0.5Cu ④ Flux: 25%Resin and 75% ethanol in weight ⑤ The chip shall be stabilized at normal condition for 1~2 hours before measuring.
10. Temperature Characteristics	① No visible mechanical damage. ② Impedance change: Within ±20%. ③ Insulation Resistance: 10MΩ Min.	① Temperature range: -40℃ to +85℃ ② Reference temperature: +20℃
11. Thermal shock	① No mechanical damage. ② Impedance change: Within ±20%. ③ Insulation Resistance: 10MΩ Min.	① Temperature and time: -40℃ for 30±3 min → 85℃ for 30±3min. ② Transforming interval: Max. 20 sec. ③ Tested cycle: 250 cycles ④ The chip shall be stabilized at normal condition for 1~2 hours before measuring. 

Chip Common Mode Choke Coil (SDCW series)

Item	Requirements	Test Methods and Remarks
12. Resistance to low temperature	① No mechanical damage. ② Impedance change: Within $\pm 20\%$ . ③ Insulation Resistance: 10M $\Omega$ Min.	① Temperature: $-40\pm 2^{\circ}\text{C}$ ② Duration: 500 <sup>+12</sup> hours ③ The chip shall be stabilized at normal condition for 1~2 hours before measuring.
13. Damp heat (Steady states)	① No visible mechanical damage. ② Impedance change: Within $\pm 20\%$ . ③ Insulation Resistance: 10M $\Omega$ Min.	① Temperature: $60\pm 2^{\circ}\text{C}$ ② Humidity: 90% to 95% RH ③ Duration: 500 <sup>+12</sup> hours ④ The chip shall be stabilized at normal condition for 1~2 hours before measuring.
14. Loading under damp heat	① No visible mechanical damage. ② Impedance change: Within $\pm 20\%$ . ③ Insulation Resistance: 10M $\Omega$ Min.	① Temperature: $60\pm 2^{\circ}\text{C}$ ② Humidity: 90% to 95% RH ③ Duration: 500 <sup>+12</sup> hours ④ Applied current: Rated current. ⑤ The chip shall be stabilized at normal condition for 1~2 hours before measuring.
15. Loading at high temperature (Life test)	① No visible mechanical damage. ② Impedance change: Within $\pm 20\%$ . ③ Insulation Resistance: 10M $\Omega$ Min.	① Temperature: $85\pm 2^{\circ}\text{C}$ ② Duration: 500 <sup>+12</sup> hours ③ Applied current: Rated current. ④ The chip shall be stabilized at normal condition for 1~2 hours before measuring.

Chip Varistor (SDV series)

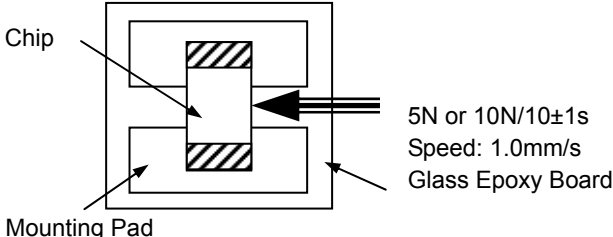
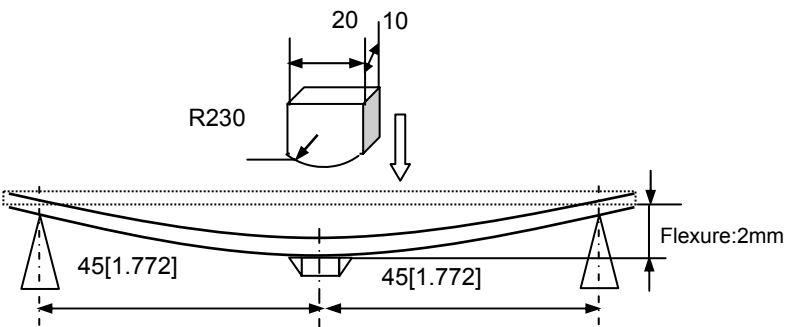
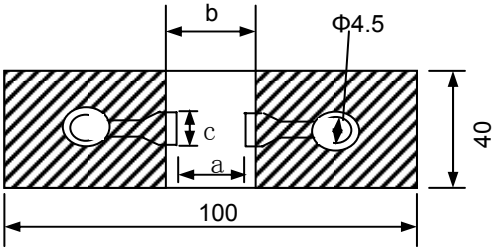
Items	Requirements	Test Methods and Remarks																				
1. Operating Temperature Range		-55°C to +125°C																				
2. Storage Temperature Range		-55°C to +125°C																				
3. Terminal Strength	No removal or split of the termination or other defects shall occur.	<p>① Solder the chip to the testing jig (glass epoxy board shown as the following figure.) using eutectic solder. Then apply a force in the direction of the arrow.</p> <p>② 5N force for 1005 and 1608 series</p> <p>③ 10N force for 2012 and 3216 series</p> <p>④ Keep time: 10±1s</p> 																				
4. Resistance to Flexure	No visible mechanical damage.	<p>① Solder the chip to the test jig (glass epoxy board) using a eutectic solder. Then apply a force in the direction shown as the following figure.</p> <p>② Flexure: 2mm</p> <p>③ Pressurizing speed: 0.5mm/sec</p> <p>④ Keep time: ≥30 sec</p>																				
 <p>Unit: mm [inch]</p> <table border="1" data-bbox="466 1568 858 1758"> <thead> <tr> <th>Type</th> <th>a</th> <th>b</th> <th>c</th> </tr> </thead> <tbody> <tr> <td>1005[0402]</td> <td>0.4</td> <td>1.5</td> <td>0.5</td> </tr> <tr> <td>1608[0603]</td> <td>1.0</td> <td>3.0</td> <td>1.2</td> </tr> <tr> <td>2012[0805]</td> <td>1.2</td> <td>4.0</td> <td>1.65</td> </tr> <tr> <td>3216[1206]</td> <td>2.2</td> <td>5.0</td> <td>2.0</td> </tr> </tbody> </table> 			Type	a	b	c	1005[0402]	0.4	1.5	0.5	1608[0603]	1.0	3.0	1.2	2012[0805]	1.2	4.0	1.65	3216[1206]	2.2	5.0	2.0
Type	a	b	c																			
1005[0402]	0.4	1.5	0.5																			
1608[0603]	1.0	3.0	1.2																			
2012[0805]	1.2	4.0	1.65																			
3216[1206]	2.2	5.0	2.0																			

Chip Varistor (SDV series)

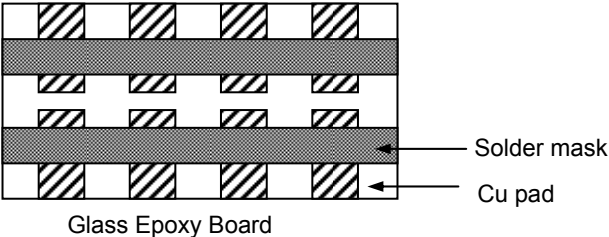
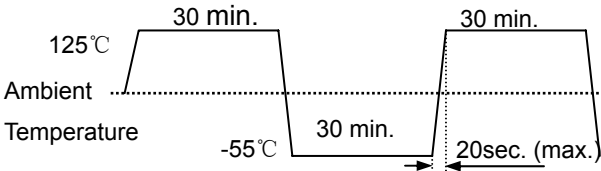
Items	Requirements	Test Methods and Remarks
5. Vibration	No visible mechanical damage.	① Solder the chip to the testing jig (glass epoxy board shown as the following figure) using eutectic solder. ② The chip shall be subjected to a simple harmonic motion having total amplitude of 1.5 mm, the frequency being varied uniformly between the approximate limits of 10 and 55 Hz. ③ The frequency range from 10 to 55 Hz and return to 10 Hz shall be traversed in approximately 1 minute. This motion shall be applied for a period of 2 hours in each 3 mutually perpendicular directions (total of 6 hours).  
6. Solderability	① No visible mechanical damage. ② Wetting shall be exceeded 90% coverage.	① Solder temperature: $240\pm 2^{\circ}\text{C}$ ② Duration: 3 sec ③ Solder: Sn/3.0Ag/0.5Cu ④ Flux: 25% Resin and 75% ethanol in weight
7. Resistance to Soldering Heat	① No visible mechanical damage. ② Varistor voltage change: Within $\pm 10\%$ .	① Solder temperature: $260\pm 3^{\circ}\text{C}$ ② Duration: 5 sec ③ Solder: Sn/3.0Ag/0.5Cu ④ Flux: 25% Resin and 75% ethanol in weight. ⑤ The chip shall be stabilized at normal condition for 1~2 hours before measuring.
8. Thermal Shock	① No visible mechanical damage. ② Varistor voltage change: Within $\pm 10\%$ .	① Temperature and time: $-55^{\circ}\text{C}$ for $30\pm 3$ min $\rightarrow$ $125^{\circ}\text{C}$ for $30\pm 3$ min ② Transforming interval: Max. 20 sec ③ Tested cycle: 100 cycles ④ The chip shall be stabilized at normal condition for 1~2 hours before measuring.  
9. Resistance to Low Temperature	① No visible mechanical damage. ② Varistor voltage change: Within $\pm 10\%$ .	① Temperature: $-55\pm 2^{\circ}\text{C}$ ② Duration: $1000^{+24}$ hours ③ The chip shall be stabilized at normal condition for 1~2 hours before measuring.
10. Damp Heat (Steady States)	① No visible mechanical damage. ② Varistor voltage change: Within $\pm 10\%$ .	① Temperature: $55\pm 2^{\circ}\text{C}$ ② Humidity: 90% to 95% RH ③ Duration: $1000^{+24}$ hours ④ The chip shall be stabilized at normal condition for 1~2 hours before measuring.

Chip Varistor (SDV series)

Items	Requirements	Test Methods and Remarks
11. Loading Under Damp Heat	① No visible mechanical damage. ② Varistor voltage change: Within $\pm 10\%$ .	① Temperature: $55\pm 2^{\circ}\text{C}$ ② Humidity: 90% to 95% RH ③ Duration: $1000^{+24}$ hours ④ Applied voltage: DC working voltage ⑤ The chip shall be stabilized at normal condition for 1~2 hours before measuring.
12. Loading at High Temperature (Life Test)	① No visible mechanical damage. ② Varistor voltage change: Within $\pm 10\%$ .	① Temperature: $125\pm 2^{\circ}\text{C}$ ② Duration: $1000^{+24}$ hours ③ Applied voltage: DC working voltage ④ The chip shall be stabilized at normal condition for 1~2 hours before measuring.
13. Maximum Surge Current	① No visible mechanical damage. ② Varistor voltage change: Within $\pm 10\%$ . IEC61000-4-5 standard 1.2/50us-8/20us voltage-current combination pulse	① Temperature: $25\pm 5^{\circ}\text{C}$ ② Humidity: 30% to 65% RH ③ Number of hit: each 1 time of +/- polarity ④ Pulse waveform: 8/20 us ⑤ Applied current: maximum surge current ( $I_P$ ) ⑥ The chip shall be stabilized at normal condition for 1~2 hours before measuring.
14. Maximum Surge Energy	① No visible mechanical damage. ② Varistor voltage shall be within $\pm 10\%$ of the initial value.. IEC61000-4-5 standard 10/1000us current pulse	① Temperature: $25\pm 5^{\circ}\text{C}$ ② Humidity: 30% to 65% RH ③ Number of hit: 1 time ④ Pulse waveform: 10/1000 us ⑤ Applied energy: maximum surge energy ( $E_T$ ) ⑥ The chip shall be stabilized at normal condition for 1~2 hours before measuring.
15. ESD Life	① No visible mechanical damage. ② Varistor voltage change: Within $\pm 10\%$ . IEC61000-4-2 standard ESD gun C=150pF R=330 $\Omega$	① Discharge: Contact discharge ② Voltage: 8000V (Level 4) ③ Polarity: +, - ④ Number: 10 times within 10 sec. ⑤ The chip shall be stabilized at normal condition for 1~2 hours before measuring.
16. ESD Test	① No visible mechanical damage. ② Varistor voltage change: Within $\pm 10\%$ . IEC61000-4-2 standard ESD gun C=150pF R=330 $\Omega$	① Discharge: Air discharge ② Voltage: 15000V (Special level) ③ Polarity: +, - ④ Number: 10 times within 10 sec. ⑤ The chip shall be stabilized at normal condition for 1~2 hours before measuring.

Chip Ferrite Inductor (SDFL series) /Chip Ceramic Inductor (SDCL series) /Chip High Frequency Inductor (SDHL series)

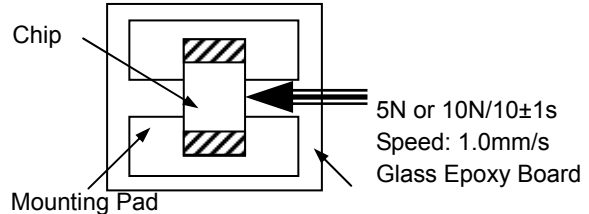
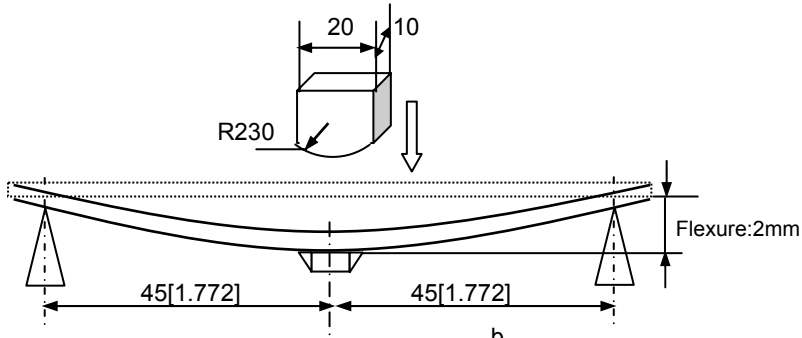
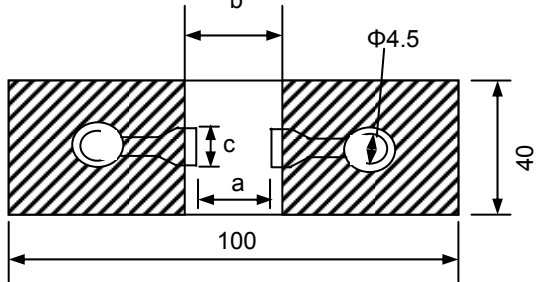
Items	Requirements	Test Methods and Remarks																				
1. Operating Temperature Range	SDFL series: -40°C to +85°C SDCL0603&1005 series: -55°C to +125°C SDCL/SDHL1608 series: -40°C to +85°C SDHL1005 series: -55°C to +125°C																					
2. Storage Temperature Range	SDFL series: -40°C to +85°C SDCL0603&1005 series: -55°C to +125°C SDCL/SDHL1608 series: -40°C to +85°C SDHL 1005series: -55°C to +125°C																					
3. Terminal Strength	No removal or split of the termination or other defects shall occur.	<p>① Solder the inductor to the testing jig (glass epoxy board shown as the following figure) using eutectic solder. Then apply a force in the direction of the arrow.</p> <p>② 5N force for 1005 and 1608 series</p> <p>③ 10N force for 2012 and 3216 series</p> <p>④ Keep time: 10±1s</p> 																				
4. Resistance to Flexure	No visible mechanical damage.	<p>① Solder the inductor to the test jig (glass epoxy board) using a eutectic solder. Then apply a force in the direction of the arrow shown as the following figure.</p> <p>② Flexure: 2mm</p> <p>③ Pressurizing Speed: 0.5mm/sec</p> <p>④ Keep time: ≥30 sec</p>																				
 <p>Unit: mm [inch]</p> <table border="1" data-bbox="391 1657 774 1803"> <thead> <tr> <th>Type</th> <th>a</th> <th>b</th> <th>c</th> </tr> </thead> <tbody> <tr> <td>1005[0402]</td> <td>0.4</td> <td>1.5</td> <td>0.5</td> </tr> <tr> <td>1608[0603]</td> <td>1.0</td> <td>3.0</td> <td>1.2</td> </tr> <tr> <td>2012[0805]</td> <td>1.2</td> <td>4.0</td> <td>1.65</td> </tr> <tr> <td>3216[1206]</td> <td>2.2</td> <td>5.0</td> <td>2.0</td> </tr> </tbody> </table> 			Type	a	b	c	1005[0402]	0.4	1.5	0.5	1608[0603]	1.0	3.0	1.2	2012[0805]	1.2	4.0	1.65	3216[1206]	2.2	5.0	2.0
Type	a	b	c																			
1005[0402]	0.4	1.5	0.5																			
1608[0603]	1.0	3.0	1.2																			
2012[0805]	1.2	4.0	1.65																			
3216[1206]	2.2	5.0	2.0																			

Chip Ferrite Inductor (SDFL series) /Chip Ceramic Inductor (SDCL series) /Chip High Frequency Inductor (SDHL series)

Items	Requirements	Test Methods and Remarks
5. Vibration	① No visible mechanical damage. ② Inductance change: Within $\pm 10\%$ ③ Q factor change: SDCL&SDHL series: Within $\pm 20\%$ , SDFL series: Within $\pm 30\%$	① Solder the inductor to the testing jig (glass epoxy board shown as the following figure) using eutectic solder. ② The inductor shall be subjected to a simple harmonic motion having total amplitude of 1.5 mm, the frequency being varied uniformly between the approximate limits of 10 and 55 Hz. ③ The frequency range from 10 to 55 Hz and return to 10 Hz shall be traversed in approximately 1 minute. This motion shall be applied for a period of 2 hours in each 3 mutually perpendicular directions (total of 6 hours).
6. Dropping	① No visible mechanical damage. ② Inductance change: Within $\pm 10\%$ ③ Q factor change: SDCL&SDHL series: Within $\pm 20\%$ , SDFL series: Within $\pm 30\%$	Drop chip inductor 10 times on a concrete floor from a height of 100 cm.
7. Temperature	Inductance change should be within $\pm 10\%$ of initial value measuring at 20°C.	Temperature range: SDFL series: $-40^{\circ}\text{C}$ to $+85^{\circ}\text{C}$ SDCL0603&1005 series: $-55^{\circ}\text{C}$ to $+125^{\circ}\text{C}$ SDCL/SDHL1608 series: $-40^{\circ}\text{C}$ to $+85^{\circ}\text{C}$ SDHL1005 series: $-55^{\circ}\text{C}$ to $+125^{\circ}\text{C}$ Reference temperature: $+20^{\circ}\text{C}$
8. Solderability	① No visible mechanical damage. ② Wetting shall be exceeded 95% coverage.	① Solder temperature: $240\pm 2^{\circ}\text{C}$ ② Duration: 3 sec. ③ Solder: Sn/3.0Ag/0.5Cu ④ Flux: 25% Resin and 75% ethanol in weight
9. Resistance to Soldering Heat	① No visible mechanical damage. ② Wetting shall be exceeded 95% coverage. ③ Inductance change: Within $\pm 10\%$ . ④ Q factor change: SDCL&SDHL series: Within $\pm 20\%$ , SDFL series: Within $\pm 30\%$	① Solder temperature: $260\pm 3^{\circ}\text{C}$ ② Duration: 5 sec. ③ Solder: Sn/3.0Ag/0.5Cu ④ Flux: 25% Resin and 75% ethanol in weight. ⑤ The chip shall be stabilized at normal condition for 1~2 hours before measuring.
10. Thermal Shock	① No visible mechanical damage. ② Inductance change: Within $\pm 10\%$ . ③ Q factor change: SDCL&SDHL series: Within $\pm 20\%$ , SDFL series: Within $\pm 30\%$ .	① Temperature and time: SDFL series and SDCL/SDHL1608 series: $-40^{\circ}\text{C}$ for $30\pm 3$ min $\rightarrow$ $85^{\circ}\text{C}$ for $30\pm 3$ min. SDCL0603&1005 series, and SDHL1005 series: $-55^{\circ}\text{C}$ for $30\pm 3$ min $\rightarrow$ $125^{\circ}\text{C}$ for $30\pm 3$ min. ② Transforming interval: Max.20 sec ③ Tested cycle: 100 cycles ④ The chip shall be stabilized at normal condition for 1~2 hours before measuring.

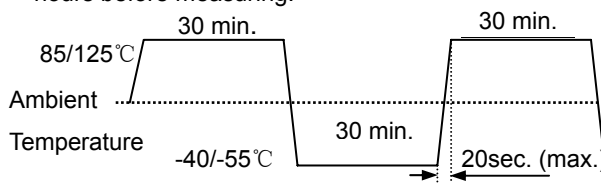

Chip Ferrite Inductor (SDFL series) /Chip Ceramic Inductor (SDCL series) /Chip High Frequency Inductor (SDHL series)

Items	Requirements	Test Methods and Remarks
11. Resistance to Low Temperature	① No visible mechanical damage. ② Inductance change: Within $\pm 10\%$ . ③ Q factor change: SDCL&SDHL series: Within $\pm 20\%$ , SDFL series: Within $\pm 30\%$ .	① Temperature: SDFL series: $-40\pm 2^{\circ}\text{C}$ SDCL0603&1005 series: $-55\pm 2^{\circ}\text{C}$ SDCL/SDHL1608 series: $-40\pm 2^{\circ}\text{C}$ SDHL 1005series: $-55\pm 2^{\circ}\text{C}$ ② Duration: $1000^{+24}$ hours ③ The chip shall be stabilized at normal condition for 1~2 hours before measuring.
12. Damp Heat (Steady States)	① No visible mechanical damage. ② Inductance change: Within $\pm 10\%$ . ③ Q factor change: SDCL&SDHL series: Within $\pm 20\%$ , SDFL series: Within $\pm 30\%$ .	① Temperature: $55\pm 2^{\circ}\text{C}$ ② Humidity: 90% to 95% RH ③ Duration: $1000^{+24}$ hours ④ The chip shall be stabilized at normal condition for 1~2 hours before measuring.
13. Loading Under Damp Heat	① No visible mechanical damage. ② Inductance change: SDCL&SDHL series: Within $\pm 10\%$ SDFL series: Within $\pm 10\%$ for inductance $\leq 12\mu\text{H}$ , Within $\pm 15\%$ for inductance $\geq 15\mu\text{H}$ . ③ Q factor change: SDCL&SDHL series: Within $\pm 20\%$ , SDFL series: Within $\pm 30\%$	① Temperature: $55\pm 2^{\circ}\text{C}$ ② Humidity: 90% to 95% RH ③ Duration: $1000^{+24}$ hours ④ Applied current: Rated current ⑤ The chip shall be stabilized at normal condition for 1~2 hours before measuring.
14. Loading at High Temperature (Life Test)	① No visible mechanical damage. ② Inductance change: SDCL&SDHL series: Within $\pm 10\%$ SDFL series: Within $\pm 10\%$ for inductance $\leq 12\mu\text{H}$ , Within $\pm 15\%$ for inductance $\geq 15\mu\text{H}$ . ③ Q factor change: SDCL&SDHL series: Within $\pm 20\%$ , SDFL series: Within $\pm 30\%$	① Temperature: SDFL series: $85\pm 2^{\circ}\text{C}$ SDCL0603&1005 series: $125\pm 2^{\circ}\text{C}$ SDCL/SDHL1608 series: $85\pm 2^{\circ}\text{C}$ SDHL1005 series: $125\pm 2^{\circ}\text{C}$ ② Duration: $1000^{+24}$ hours ③ Applied current: Rated current ④ The chip shall be stabilized at normal condition for 1~2 hours before measuring.

Chip Wire Wound Inductors (SDWL series)

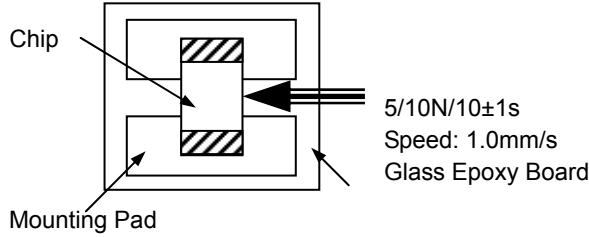
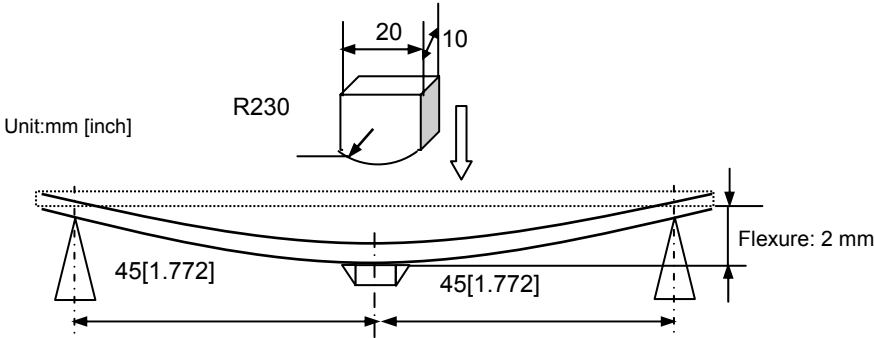
Items	Requirements	Test Methods and Remarks
1. Operating Temperature Range	-40°C to + 125°C	
2. Storage Temperature Range	-40°C to + 125°C	
3. Terminal Strength	No removal or split of the termination or other defects shall occur.	<p>① Solder the inductor to the testing jig (glass epoxy board shown as the following figure) using eutectic solder. Then apply a force in the direction of the arrow.</p> <p>② 5N force for 1005, 1608 series</p> <p>③ 10N force for 2012, 2520, 3225 and 4532 series</p> <p>④ Keep time: 10±1s</p> 
4. Resistance to Flexure	No visible mechanical damage.	<p>① Solder the inductor to the test jig (glass epoxy board) using a eutectic solder. Then apply a force in the direction shown as the following figure.</p> <p>② Flexure: 2mm</p> <p>③ Pressurizing Speed: 0.5mm/sec</p> <p>④ Keep time: ≥30 sec.</p> 

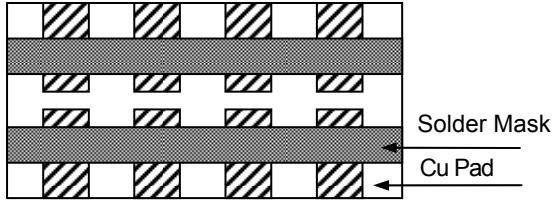
5. Vibration	① No visible mechanical damage. ② Inductance change: Within $\pm 10\%$	① Solder the inductor to the testing jig (glass epoxy board shown as the following figure) using eutectic solder. ② The inductor shall be subjected to a simple harmonic motion having total amplitude of 1.5 mm, the frequency being varied uniformly between the approximate limits of 10 and 55 Hz. ③ The frequency range from 10 to 55 Hz and return to 10 Hz shall be traversed in approximately 1 minute. This motion shall be for a period of 2 hours in each 3 mutually perpendicular directions (total of 6 hours) <div style="text-align: center;">  <p style="text-align: right;">Solder Mask Cu Pad</p> <p style="text-align: center;">Glass Epoxy Board</p> </div>
--------------	---	---

## 信赖性及测试条件

## RELIABILITY AND TEST CONDITIONS

### Chip Wire Wound Inductors (SDWL series)

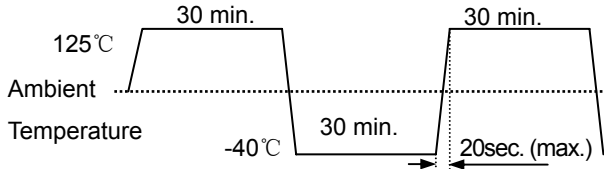
Items	Requirements	Test Methods and Remarks
6. Dropping	① No visible mechanical damage. ② Inductance change: Within $\pm 10\%$	Drop chip inductor 10 times on a concrete floor from a height of 100 cm.
7. Temperature	Inductance change should be within $\pm 10\%$ of initial value measuring at 20°C.	Temperature range: -40°C to +85°C Reference temperature: +20°C
8. Solderability	① No visible mechanical damage. ② Wetting shall be exceeded 90% coverage.	① Solder temperature: 240 $\pm$ 2°C ② Duration: 3 sec ③ Solder: Sn/3.0Ag/0.5Cu ④ Flux: 25% Resin and 75% ethanol in weight
9. Resistance to Soldering Heat	① No visible mechanical damage. ② Inductance change: Within $\pm 10\%$	① Solder temperature: 260 $\pm$ 3°C ② Duration: 5 sec ③ Solder: Sn/3.0Ag/0.5Cu ④ Flux: 25% Resin and 75% ethanol in weight ⑤ The chip shall be stabilized at normal condition for 1~2 hours before measuring.
10. Thermal Shock	① No visible mechanical damage. ② Inductance change: Within $\pm 10\%$	① Temperature and Time: -40°C for 30 $\pm$ 3 min $\rightarrow$ 125°C for 30 $\pm$ 3min. ② Transforming interval: Max. 20 sec. ③ Tested cycle: 100 cycles ④ The chip shall be stabilized at normal condition for 1~2 hours before measuring. <div style="text-align: center;">  </div>
11. Resistance to Low Temperature	① No visible mechanical damage. ② Inductance change: Within $\pm 10\%$	① Temperature: -40 $\pm$ 2°C ② Duration: 1000 <sup>+24</sup> hours; ③ The chip shall be stabilized at normal condition for 1~2 hours before measuring.

12. Damp Heat (Steady States)	<ul style="list-style-type: none"> <li>① No visible mechanical damage.</li> <li>② Inductance change: Within <math>\pm 10\%</math></li> </ul>	<ul style="list-style-type: none"> <li>① Temperature: <math>55\pm 2^{\circ}\text{C}</math></li> <li>② Humidity: 90% to 95% RH</li> <li>③ Duration: <math>1000^{+24}</math> hours</li> <li>④ The chip shall be stabilized at normal condition for 1~2 hours before measuring.</li> </ul>
13. Loading Under Damp Heat	<ul style="list-style-type: none"> <li>① No visible mechanical damage.</li> <li>② Inductance change: Within <math>\pm 10\%</math></li> </ul>	<ul style="list-style-type: none"> <li>① Temperature: <math>55\pm 2^{\circ}\text{C}</math></li> <li>② Humidity: 90% to 95% RH</li> <li>③ Duration: <math>1000^{+24}</math> hours</li> <li>④ Applied current: Rated current.</li> <li>⑤ The chip shall be stabilized at normal condition for 1~2 hours before measuring.</li> </ul>
14. Loading at High Temperature (LifeTest)	<ul style="list-style-type: none"> <li>① No visible mechanical damage.</li> <li>② Inductance change: Within <math>\pm 10\%</math></li> </ul>	<ul style="list-style-type: none"> <li>① Temperature: <math>125\pm 2^{\circ}\text{C}</math></li> <li>② Duration: <math>1000^{+24}</math> hours</li> <li>③ Applied current: Rated current.</li> <li>④ The chip shall be stabilized at normal condition for 1~2 hours before measuring.</li> </ul>

### 信赖性及测试条件

### RELIABILITY AND TEST CONDITIONS

#### Chip NTC Thermistor (SDNT series)

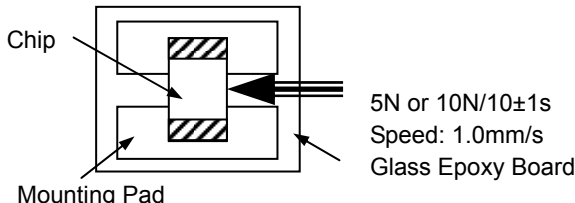
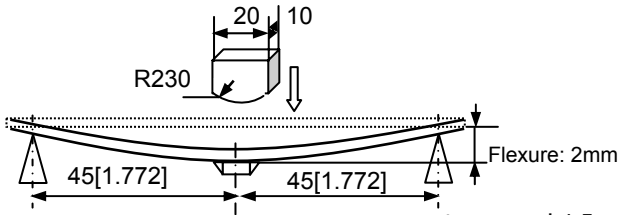
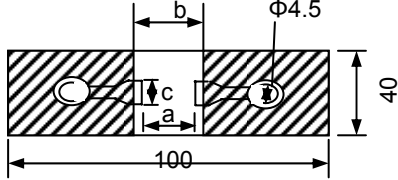
Items	Requirements	Test Methods and Remarks																
1. Operating Temperature Range		-55°C to +125°C																
2. Storage Temperature Range		-55°C to +125°C																
3. Terminal Strength	No removal or split of the termination or other defects shall occur.	<ul style="list-style-type: none"> <li>① Solder the chip to the testing jig (glass epoxy board shown as the following figure) using eutectic solder. Then apply a force in the direction of the arrow.</li> <li>② 5N force for 1005 and 1608 series</li> <li>③ 10N force for 2012 series</li> <li>④ Keep time : <math>10\pm 1\text{s}</math></li> </ul> 																
4. Resistance to Flexure	No visible mechanical damage.	<ul style="list-style-type: none"> <li>① Solder the chip to the test jig (glass epoxy board ) using a eutectic solder. Then apply a force in the direction shown as the following figure.</li> <li>② Flexure: 2mm</li> <li>③ Pressurizing Speed: 0.5mm/sec</li> <li>④ Keep time: <math>\geq 30\text{ sec.}</math></li> </ul>  <div style="margin-top: 10px;"> <p>Unit: mm [inch]</p> <table border="1" style="display: inline-table; margin-right: 20px;"> <thead> <tr> <th>Type</th> <th>a</th> <th>b</th> <th>c</th> </tr> </thead> <tbody> <tr> <td>1005[0402]</td> <td>0.4</td> <td>1.5</td> <td>0.5</td> </tr> <tr> <td>1608[0603]</td> <td>1.0</td> <td>3.0</td> <td>1.2</td> </tr> <tr> <td>2012[0805]</td> <td>1.2</td> <td>4.0</td> <td>1.65</td> </tr> </tbody> </table>  </div>	Type	a	b	c	1005[0402]	0.4	1.5	0.5	1608[0603]	1.0	3.0	1.2	2012[0805]	1.2	4.0	1.65
Type	a	b	c															
1005[0402]	0.4	1.5	0.5															
1608[0603]	1.0	3.0	1.2															
2012[0805]	1.2	4.0	1.65															

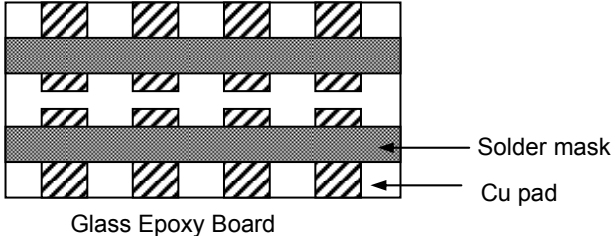
5. Vibration	No visible mechanical damage.	<ol style="list-style-type: none"> <li>① Solder the chip to the testing jig (glass epoxy board shown as the following figure) using eutectic solder.</li> <li>② The chip shall be subjected to a simple harmonic motion having total amplitude of 1.5 mm, the frequency being varied uniformly between the approximate limits of 10 and 55 Hz.</li> <li>③ The frequency range from 10 to 55 Hz and return to 10 Hz shall be traversed in approximately 1 minute. This motion shall be applied for a period of 2 hours in each 3 mutually perpendicular directions (total of 6 hours)</li> </ol>  <p style="text-align: center;">Glass Epoxy Board</p> <p style="text-align: right;">Solder mask Cu pad</p>
6. Dropping	No visible mechanical damage.	Drop the chip 10 times on a concrete floor from a height of 100 cm.

**信赖性及测试条件**

**RELIABILITY AND TEST CONDITIONS**

Chip NTC Thermistor (SDNT series)

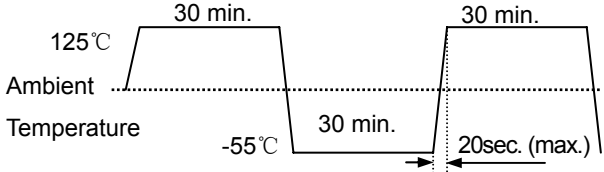
Items	Requirements	Test Methods and Remarks
7. Solderability	<ol style="list-style-type: none"> <li>① No visible mechanical damage.</li> <li>② Wetting shall be exceeded 80% coverage.</li> </ol>	<ol style="list-style-type: none"> <li>① Solder temperature: 240±2°C</li> <li>② Duration: 3 sec</li> <li>③ Solder: Sn/3.0Ag/0.5Cu</li> <li>④ Flux: 25% Resin and 75% ethanol in weight</li> </ol>
8. Resistance Soldering Heat	<ol style="list-style-type: none"> <li>① No visible mechanical damage.</li> <li>② R25 change: Within ±5%.</li> <li>③ B constant change: Within ±2%.</li> </ol>	<ol style="list-style-type: none"> <li>① Solder temperature: 260±3°C</li> <li>② Duration: 5 sec</li> <li>③ Solder: Sn/3.0Ag/0.5Cu</li> <li>④ Flux: 25% Resin and 75% ethanol in weight.</li> <li>⑤ The chip shall be stabilized at normal condition for 1~2 hours before measuring.</li> </ol>
9. Thermal Shock	<ol style="list-style-type: none"> <li>① No visible mechanical damage.</li> <li>② R25 change: Within ±5%.</li> <li>③ B constant change: Within ±2%.</li> </ol>	<ol style="list-style-type: none"> <li>① Temperature and time: -55°C for 30±3 min→125°C for 30±3min.</li> <li>② Transforming interval: Max.20 sec.</li> <li>③ Tested cycle: 100 cycles</li> <li>④ The chip shall be stabilized at normal condition for 1~2 hours before measuring.</li> </ol> 
10. Resistance to Low Temperature	<ol style="list-style-type: none"> <li>① No visible mechanical damage.</li> <li>② R25 change: Within ±5%.</li> <li>③ B constant change: Within ±2%.</li> </ol>	<ol style="list-style-type: none"> <li>① Temperature: -55±2°C</li> <li>② Duration: 1000<sup>+24</sup> hours</li> <li>③ The chip shall be stabilized at normal condition for 1~2 hours before measuring.</li> </ol>

<p>11. Damp Heat (Steady States)</p>	<p>① No visible mechanical damage. ② R25 change: Within <math>\pm 5\%</math>. ③ B constant change: Within <math>\pm 2\%</math>.</p>	<p>① Temperature: <math>55 \pm 2</math> °C ② Humidity: 90% to 95% RH ③ Duration: 1000<sup>+24</sup> hours ④ The chip shall be stabilized at normal condition for 1~2 hours before measuring.</p>
<p>12. High Temperature Life Test</p>	<p>① No visible mechanical damage. ② R25 change: Within <math>\pm 5\%</math>. ③ B constant change: Within <math>\pm 2\%</math>.</p>	<p>① Temperature: <math>125 \pm 2</math> °C ② Humidity: 90% to 95% RH ③ Duration: 1000<sup>+24</sup> hours ④ The chip shall be stabilized at normal condition for 1~2 hours before measuring.</p>